

GIANTMIX FT TOP

FT3 110-275

FT4 150-275

FT4 150-400

FT5 185-275

FT5 185-400

FT6 220-400

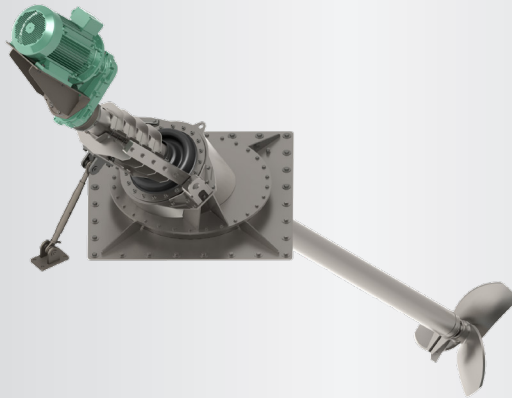



Application

Long-axis agitator for closed tanks
Dry matter content up to 14 %
Substrate temperature up to 70°C
pH-value 6.5 - 8.2

Technical Data

Tube length 4.0 / 5.0 / 5.5 / 6.0 m
Tube Ø 159 x 5 mm, ss304
inclusive robust tube within tube technology
Sealing plate 120 x 120 cm (143x143), ss304
ss316 on request
Sound pressure level 75 dB(A)
Sealing membranes of EPDM60
Oil inspection glass for monitoring the tightness
Agitator completely manufactured in modular design
POM protection to minimize abrasion

Motor

4-poles (IE3 motor)
400 V, 50 Hz, special voltages on request
PTC thermistors (overheat protection)
Ex-Motor  II 3G Ex nA IIA T3 Gc
Special design 13.5 kW:  II 2G Ex eb IIC T3 Gb
Option: rain protection hood (ss304)

Gear

Planetary gear, helical teeth, low noise level
Reduction ratio $i = 3.69$ or 5.31
Own oil circuit gear oil SAE85W-140 / API GL-5
Oil change all 2,000 operating hours

Bearing

2 tapered roller bearing to absorb the axial forces
Mechanical seals SiC/SiC, independent of rotation direction
Interim bearings for the drive shaft (slide bearings)

Propeller

3-blade high efficiency propeller, dynamically balanced

FT3:	11.0 kW	275 rpm	Propeller HD+ 800
FT4:	15.0 kW	275 rpm	Propeller HD+ 850
FT4:	15.0 kW	400 rpm	Propeller HD+ 660
FT5:	18.5 kW	275 rpm	Propeller HD+ 880
FT5:	18.5 kW	400 rpm	Propeller HD+ 700
FT6:	22.0 kW	400 rpm	Propeller HD+ 750

ss304, optional ss316 or hardened steel

Tank openings

800 x 800 mm (plate 120 cm)
1,000 x 1,000 mm (plate 143 cm)

Ex-Zone

Ex-Zone 2 (outside tank) and Zone 1 (inside tank)
Special design FT4 13.5 kW for Zone 1 (outside)

Classification mechanical components:

  II 2G Ex h IIA T3 Gb

Control switch (optional)

Soft start or frequency converter
Delivery without connecting cable



بسیارازین پارس

نمایندگی ایران

تلفن تماس: ۸ و ۰۲۱ - ۸۸۳۲۴۹۳۷

GIANTMIX FT TOP



بیوسازاین پارس

نمایندگی ایران

تلفن تماس: ۸ و ۰۲۱ - ۸۸۳۲۴۹۳۷

E-mail: sales@brp.co.ir

FT3 110-275

FT4 150-275

FT4 150-400

FT5 185-275

FT5 185-400

FT6 220-400

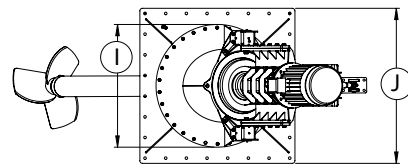
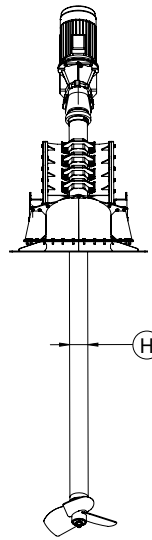
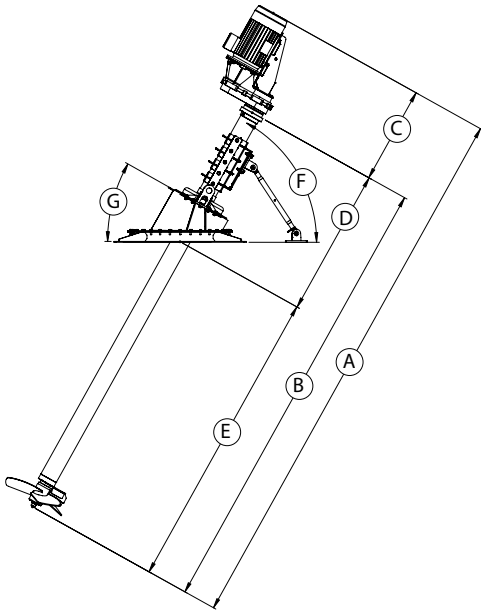

Dimensions

Type	A [m]	B [m]	C [m]	D [m]	E [m]	F	G	H [Ø in mm]	I [Ø in mm]	J [m]
FT 4-6 (400 rpm)	4.5 / 5.5	4.0 / 5.0	0.88	1.34	3.0 / 4.0 / 4.5 / 5.0	max 60°	30°	159	950	1.20
FT 3-5 (275 rpm)	6.0 / 6.5	5.5 / 6.0								1.43

Technical data

Type	Rated Power [kW]	Propeller speed [rpm]	Rated Voltage [V]	Rated current [A]	Frequency [Hz]	Power factor cos φ	Gear reduction ratio	Propeller diameter [mm]	Axial force [kN]	Flow velocity [m/s] *	Pumping rate water [m ³ /min]	Weight approximate [kg]
FT3	11.0	275	400	19.6	50	0.88	5.31	800	2.9	3.2	95	850
FT4	15.0	275	400	28.3	50	0.83	5.31	850	4.1	3.6	119	850
FT4	15.0	400	400	28.3	50	0.83	3.69	660	3.3	4.3	84	850
FT5	18.5	275	400	33.7	50	0.85	5.31	880	4.4	3.7	132	850
FT5	18.5	400	400	33.7	50	0.85	3.69	700	3.9	4.3	94	850
FT6	22.0	400	400	41.0	50	0.83	3.69	750	4.5	4.5	115	850

Subject to technical changes

* measured in water and 1.2 m distance

As per: 2022-06