

REKORDMIX B1

B1 40-950



Application

Dry matter content up to 10 %
Substrate temperature up to 70°C
pH-values 6.5 - 8.2

Technical data

Tube length 3.75 / 4.25 m
Safety ring
Oil equalizing container for monitoring the tightness
Sound pressure level 72 dB(A)
Agitator completely manufactured in modular design

Motor

Power: 4.0 kW
400 V, 50 Hz, 950 rpm
PTC thermistors for overheat protection
Ex-Motor  II 3G Ex nA IIA T3 Gc (ex-zone 2)

Bearing

2 tapered roller bearings to absorb the axial forces
Mechanical seal in SiC/SiC,
- independent of rotation direction
Interim bearings for the drive shaft



Tube

Tube Ø 70 x 3 mm in ss304
Stub shaft Ø 20 mm with intermediate bearings and both sided plug-connection
Tube is completely filled with sealing oil ISO VG68

Propeller

2-bladed propeller with safety ring
B1: 4.0 kW | propeller L4 (320 mm) | 950 rpm
Galvanized or ss304

Ex-zone

Ex-zone 2 (outside the tank) and zone 1 (inside the tank)
Classification mechanical components
  II 2G Ex h IIA T3 Gb

Control box (optional)

Soft start - frequency converter
Delivery without connecting cable



بسیار ایزن پارس

نمایندگی ایران

تلفن تماس : ۸ و ۸۸۳۲۴۹۳۷ - ۰۲۱

E-mail : sales@brp.co.ir

REKORDMIX B1

B1 40-950

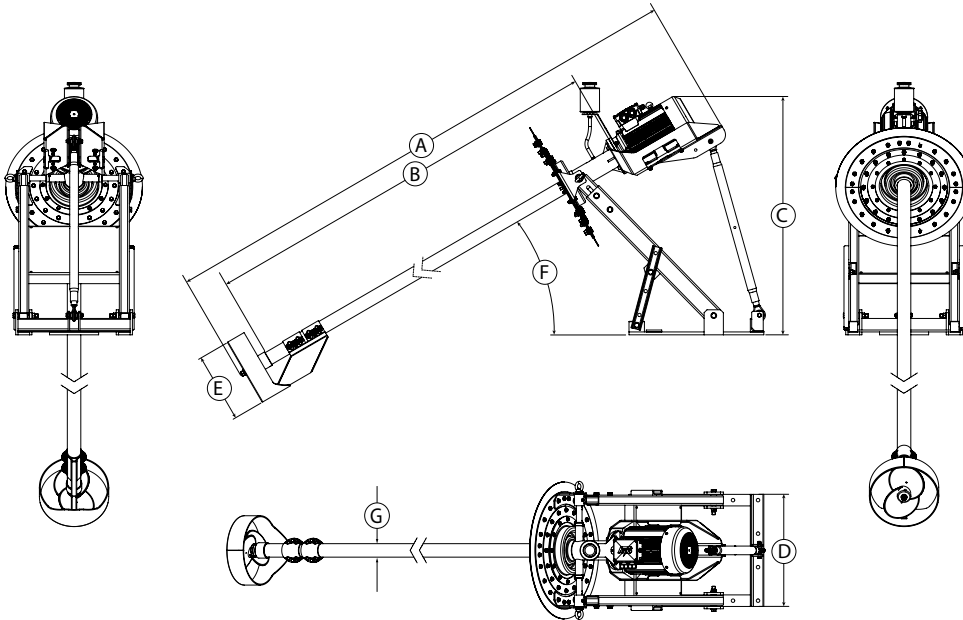

نمایندگی ایران

تلفن تماس: ۸ و ۰۲۱ - ۸۸۲۲۴۹۳۷

E-mail: sales@brp.co.ir

Dimensions

Type	A [mm]	B [mm]	C [mm]	D [mm]	E [mm]	F	G [Ø in mm]
B1	4,400 / 4,900	3,700 / 4,200	1,235	725	355	30°	70

Technical data

Type	Rated Power [kW]	Rated Voltage [V]	Rated Current [A]	Frequency [Hz]	Power Factor cos φ	Propeller speed [rpm]	Propeller diameter [mm]	Axial force [kN]	Flow velocity [m/s] *	Pumping rate Water [m ³ /min]	Weight approximate [kg]
B1	4.0	400	9.8	50	0.72	950	320	0.6	4.0	18	205

Subject to technical changes

* measured in water and 1.2 m distance